

DRINKOTEC

Switzerland



Vending Catalog 2024

Vending & dispensing equipments
Data & AI apps

Less waste and more profits
in your beverage operations
from cellar to cloud

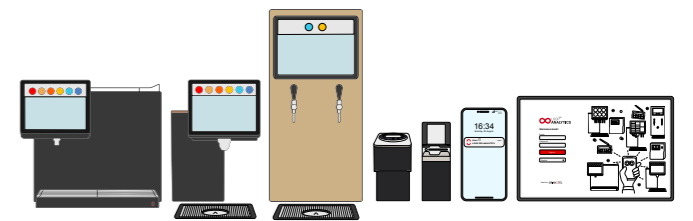
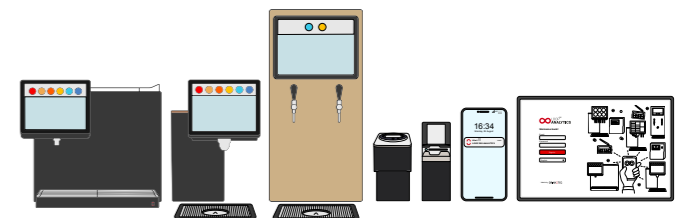

Table of contents

5	Vending & self-service
6	NEO
10	Vision PX
14	The Wall
20	BevPay
27	Data & AI apps
28	Drinkotec IoT Infrastructure
30	Loop ³⁶⁰ Analytics
35	Counter cutting drawings
36	NEO
37	Vision PX
38	The Wall
40	BevPay





Vending Self-service

Beverage operations for

- Workplaces
- Coffee Corners
- Break rooms
- QSR
- Collectivities
- Cafeterias
- Arenas
- Convenience Stores

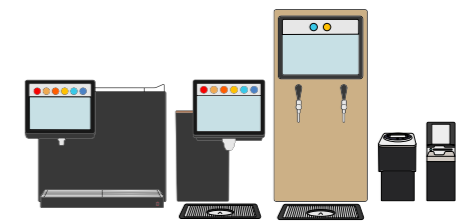



Simplicity matters

Towards net-zero transition

SOFT DRINKS

The ultimate counter-top **all-in-one postmix dispenser**. It fits locations that have limited space for chillers and storage of postmix drinks.

This **micro factory for soft drinks** uses postmix dosing technology which allows to create and personalize **your own mix**.

- ✓ 4 flavours in Bag-in-Box (ratio up to 1:10)
- ✓ Unlimited custom recipes
- ✓ Throughput 80 drinks per hour*
- ✓ Self-Payment ready
- ✓ Remote monitoring
- ✓ Remote settings capabilities
- ✓ Video content management

*In ideal conditions:
ambient operating temperature = 24°C
syrup storage temperature = 24°C
water in temperature = 16°C

Main features

- ✓ Small footprint
538 mm depth
- ✓ Ratios up to 1:100 highly concentrated aromas*
- ✓ Tabletop dispenser with integrated cooler and carbonation
- ✓ 12" touch screen
- ✓ Adaptable syrup/water ratio up 1:10
- ✓ Customizable portions and prices



Connected equipment to Loop³⁶⁰ Analytics



Dimensions

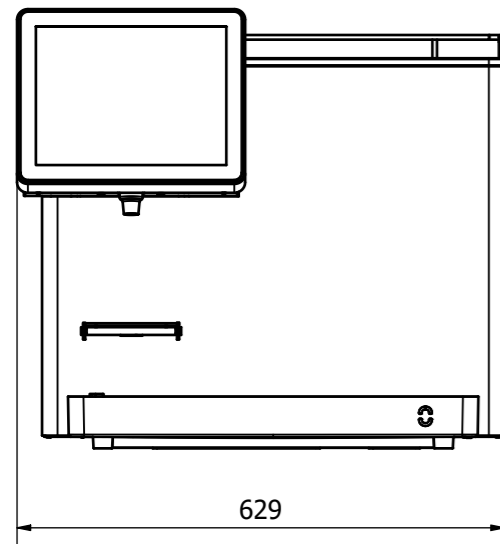

Front view

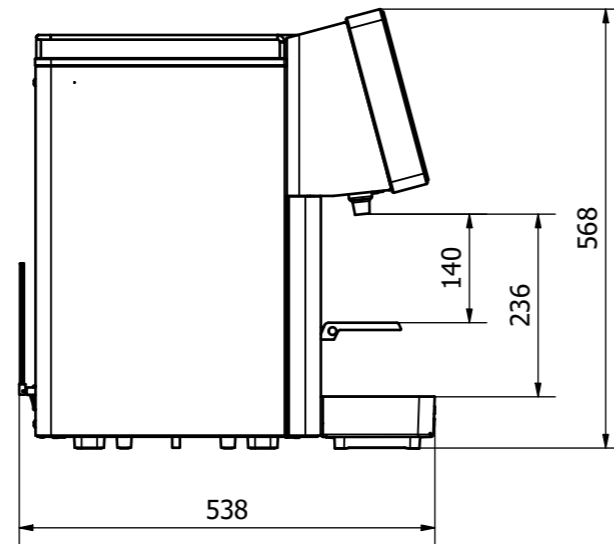

Lateral left view

Technical features

Physical data

height: 568 mm
width: 629 mm
depth: 538 mm
dispense height cup-holder: 140 mm
dispense height tray: 236 mm
waterbath capacity: 9 L
dry weight: 52 kg
operating weight: 66 kg
noise level: <70 dB (A)

Water pressure & CO₂

H₂O min: 1.5 Bar
H₂O max: 3.5 Bar
CO₂ min: 4 Bar
CO₂ max: 4.5 Bar

Carbonation system

carbonator pump:
454 L/h brass rotary vane
carbonator pump motor:
150 W induction motor 1400 RPM
carbonator bowl fill rate:
nominal 3.0 L/min @ 5.5 Bar CO₂
pressure
carbonator bowl reserve: 0.6 L

Electrical data

mains voltage:
male plug type F / type J
100-240 V
frequency: 50 Hz
current: 3.5 A
power: 660 W
fuse rating and prise:
10 A 20 mm HRC

Refrigeration

duty @ -10°C evaporation: 250 W
refrigerant: R290
refrigerant charge: 75 g

System protection

compressor/carbonator pump
/recirculation pump/agitator:
self resetting thermal trip
carbonation system:
carb pump time out - 4 mins

NEO

Technical specifications

Back room requirements

The Bag-in-Boxes must be stored below or at the same level as the dispensing unit, and **within 2 meters** of it.

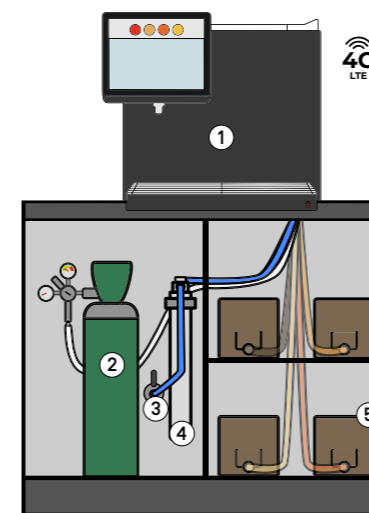

NEO 4 postmix flavours

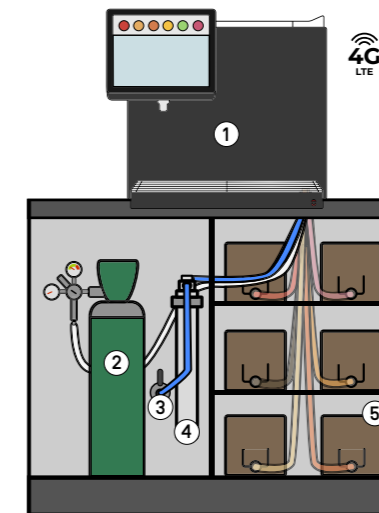

NEO 6 postmix flavours

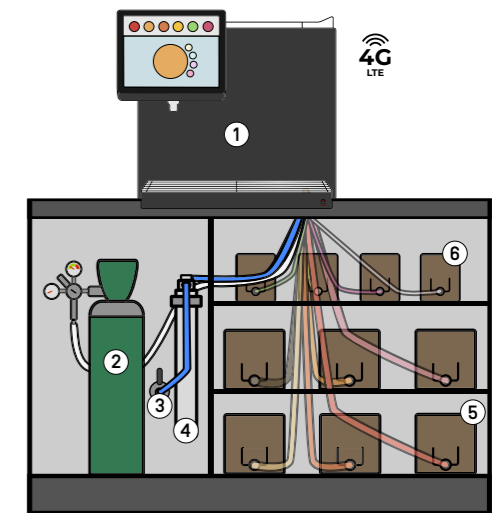

NEO 6 postmix flavours
with aroma dosing technology

1 - NEO
2 - CO₂ bottle
3 - Water inlet
4 - Water filter
5 - Postmix Bag-in-Boxes
6 - Aroma add-ons



VISION PX



Performance matters

Footprint optimized

SOFT DRINKS

Vision PX, a small footprint for maximum performance soft drinks dispensing.

With his simple esthetic, Vision PX can be installed in any interior design.

- ✓ 4 to 8 flavours in Bag-in-Box (ratio up to 1:8)
- ✓ Throughput 130 drinks per hour*
- ✓ Self-Payment ready
- ✓ Remote settings capabilities
- ✓ Video content management

*With an Icecore 15 by Welbilt: 130 drinks of 50 cL, optimized ambient operating temperature = 24°C

The volume depends on the cooler's specification. Contact us for more information.



Connected equipment to Loop³⁶⁰ Analytics



Dimensions

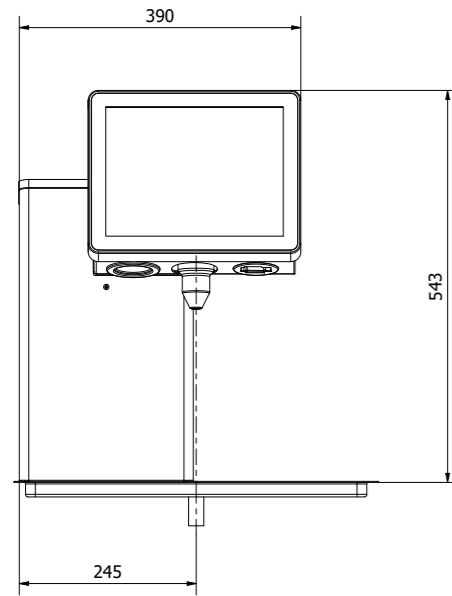

Front view

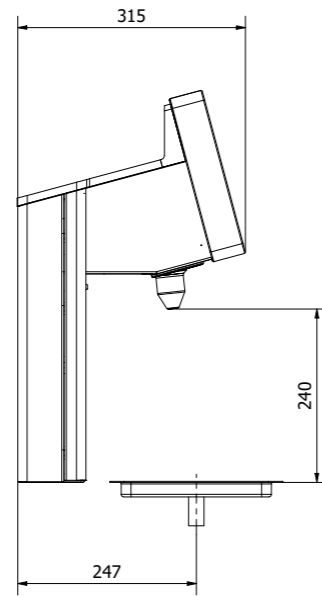

Lateral left view

Main features

- ✓ **Small footprint**
315 mm depth
- ✓ **Easy cleaning**
with one single nozzle
- ✓ **4 to 8 ingredients & unlimited recipes**
- ✓ **12" touch screen**
- ✓ **Customizable portions and prices**

Technical features

- ✓ **Physical data**
height: 543 mm
width: 390 mm
depth: 315 mm
weight: 15.5 kg
- ✓ **Electrical data**
mains voltage:
male plug type F / type J 100-240 V
frequency: 50 Hz
power: 90 W
AC current:
0.95A@115VAC
0.5A@230VAC
0.4A@277VAC

- ✓ **Water pressure & CO₂**
H₂O min: 1.5 Bar
H₂O max: 3.5 Bar
CO₂ min: 4.5 Bar
CO₂ max: 5.5 Bar

Back room requirements

- 1 - Vision PX
- 2 - Cooler
- 3 - Compressor
- 4 - Syrup pumps
- 5 - Postmix Bag-in-Boxes
- 6 - Water filter
- 7 - Water inlet
- 8 - CO₂ bottle

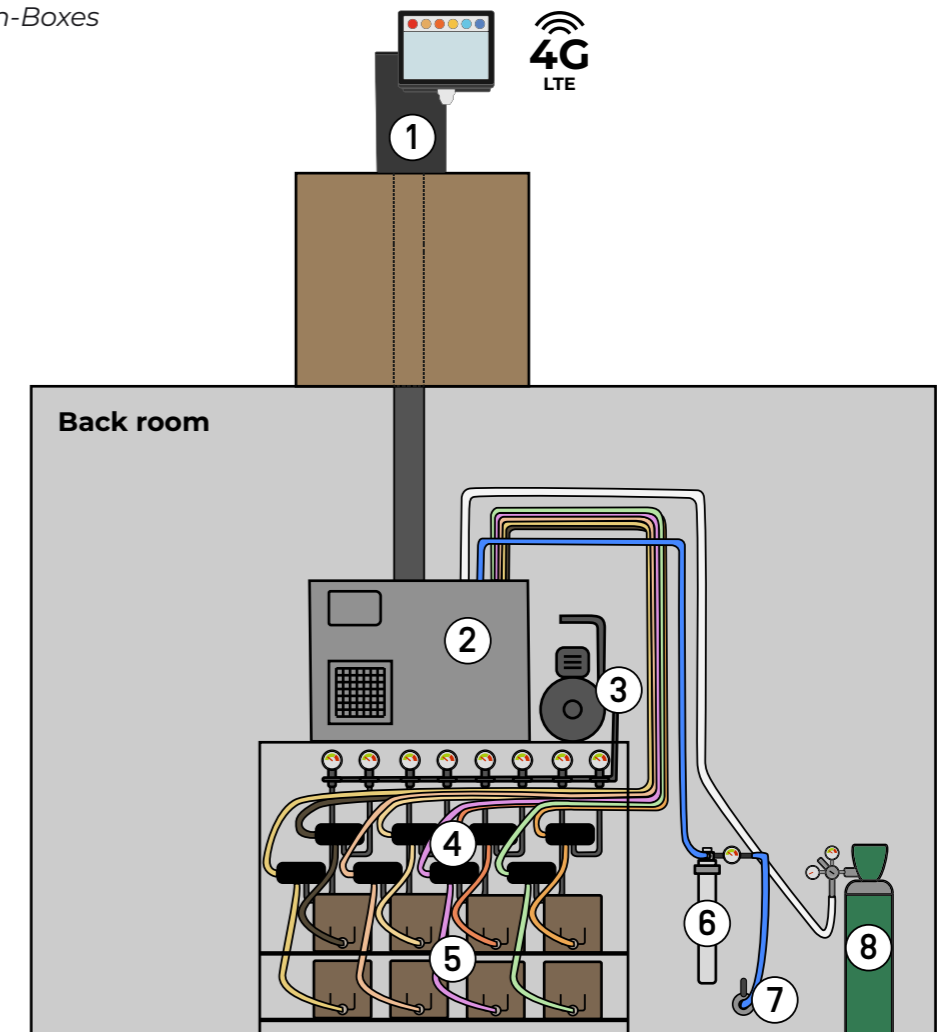

Non-contractual layout



THE WALL



Enhanced customer experience matters ————— The power of self-service

SOFT DRINKS | BEER | WINE

The wall offers you **multiplication** of point of dispensing in your venue.

This will allow you to **increase your sales drastically** and **manage very high demand**.

- ✓ Self-service
- ✓ Premix or postmix
- ✓ Countertop or integrated
- ✓ Push & pour or portion dispensing
- ✓ Self-Payment ready
- ✓ Video content management



Kit
Fits your own wall design

4G
LTE
Connected equipment
to Loop³⁶⁰ Analytics



Countertop
"Tower-like" installation

Dimensions

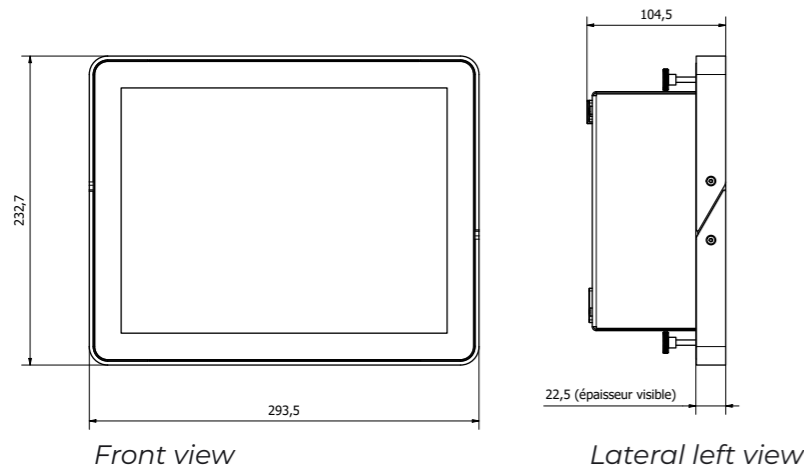

Postmix & premix taps available for each version.

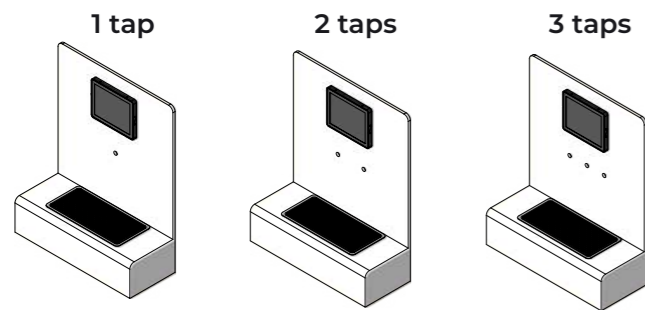

Main features

- ✓ Up to 3 taps for one 12" touch screen
- ✓ Premix or postmix beverages
- ✓ Customizable portions and prices

Technical features

- ✓ **Electrical data**
tension: 100-240 V
frequency: 50 Hz
current: 3.5 A
power: 90 W
- ✓ **Physical data Kit screen**
height: 232,7 mm
width: 293,5 mm
depth: 104,5 mm
weight: 2 kg

Included in Kit

- Touch screen & UI controller
- Your tap choice between **postmix** & **premix** (1, 2 or 3 taps)



THE WALL KIT

Technical specifications

Back room requirements

- 1 - The Wall Kit - one tap
- 2 - The Wall Kit - two taps
- 3 - The Wall Kit - three taps
- 4 - Cooler
- 5 - Premix kegs
- 6 - CO₂ bottle

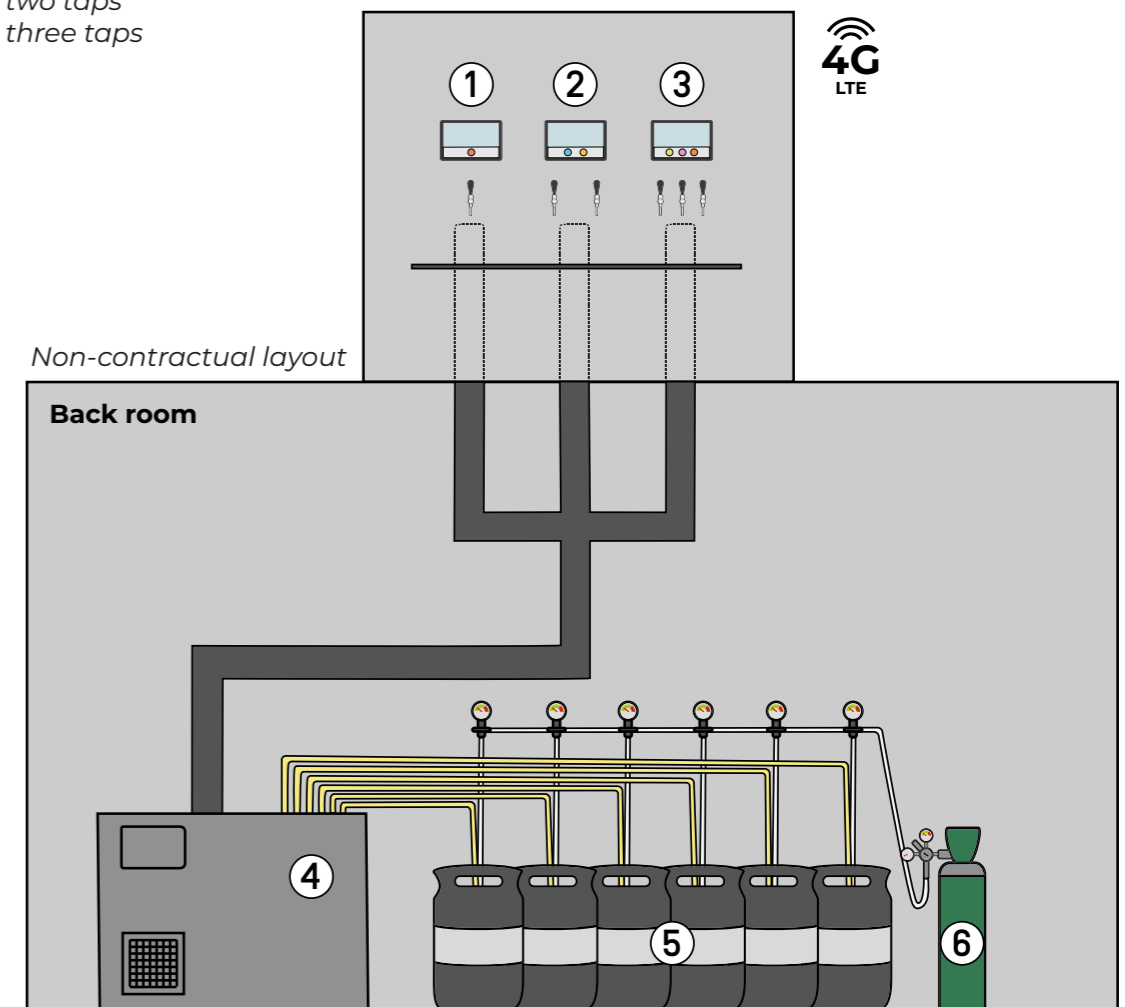

Allow space for pipes! Recommended distance between the floor and the tap: 1'160 mm (min.) & 1'260 mm (max).

Dimensions

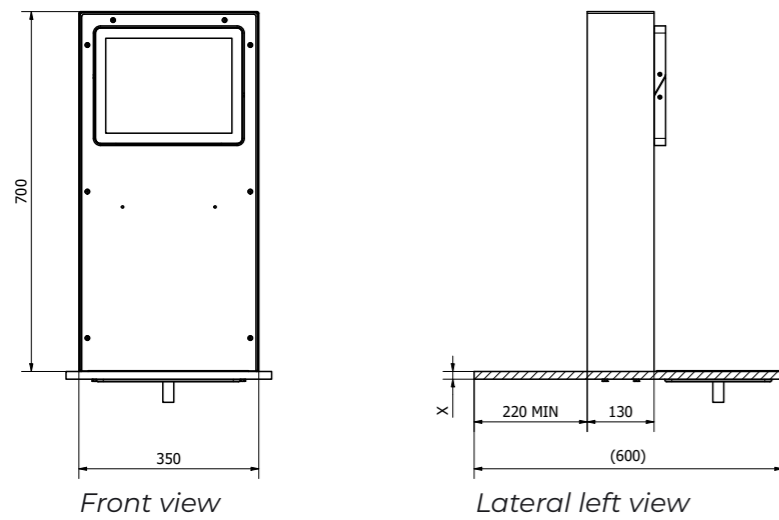

Postmix & premix taps available for each version.

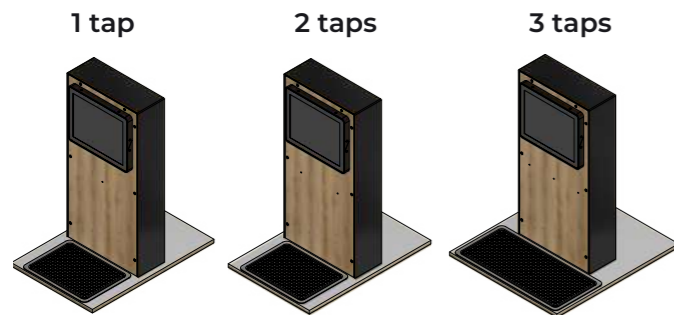

Main features

- ✓ Up to 3 taps for one 12" touch screen
- ✓ Premix or postmix beverages
- ✓ Customizable portions and prices

Technical features

- ✓ Electrical data
tension: 100-240 V
frequency: 50 Hz
current: 3.5 A
power: 90 W
- ✓ Physical data Countertop
height: 700 mm
width: 350 mm
depth: 233 mm
weight: 17 kg

Included

- Body with screen
- Your tap choice between **postmix & premix** (1, 2 or 3 taps)

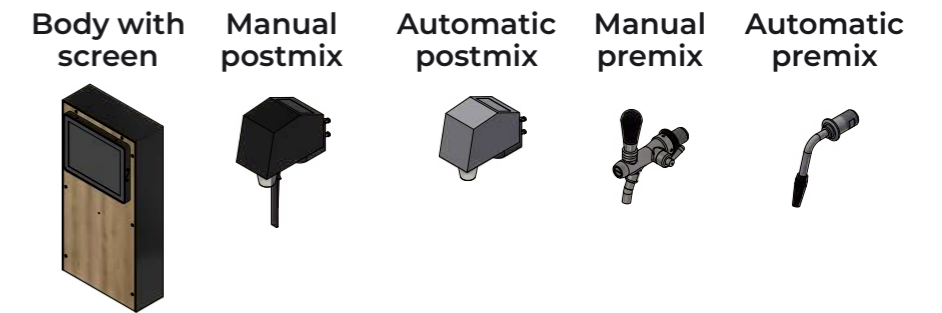

Back room requirements

- 1 - The Wall Countertop - one tap
- 2 - The Wall Countertop - two taps
- 3 - The Wall Countertop - three taps
- 4 - Cooler
- 5 - Premix kegs
- 6 - CO₂ bottle

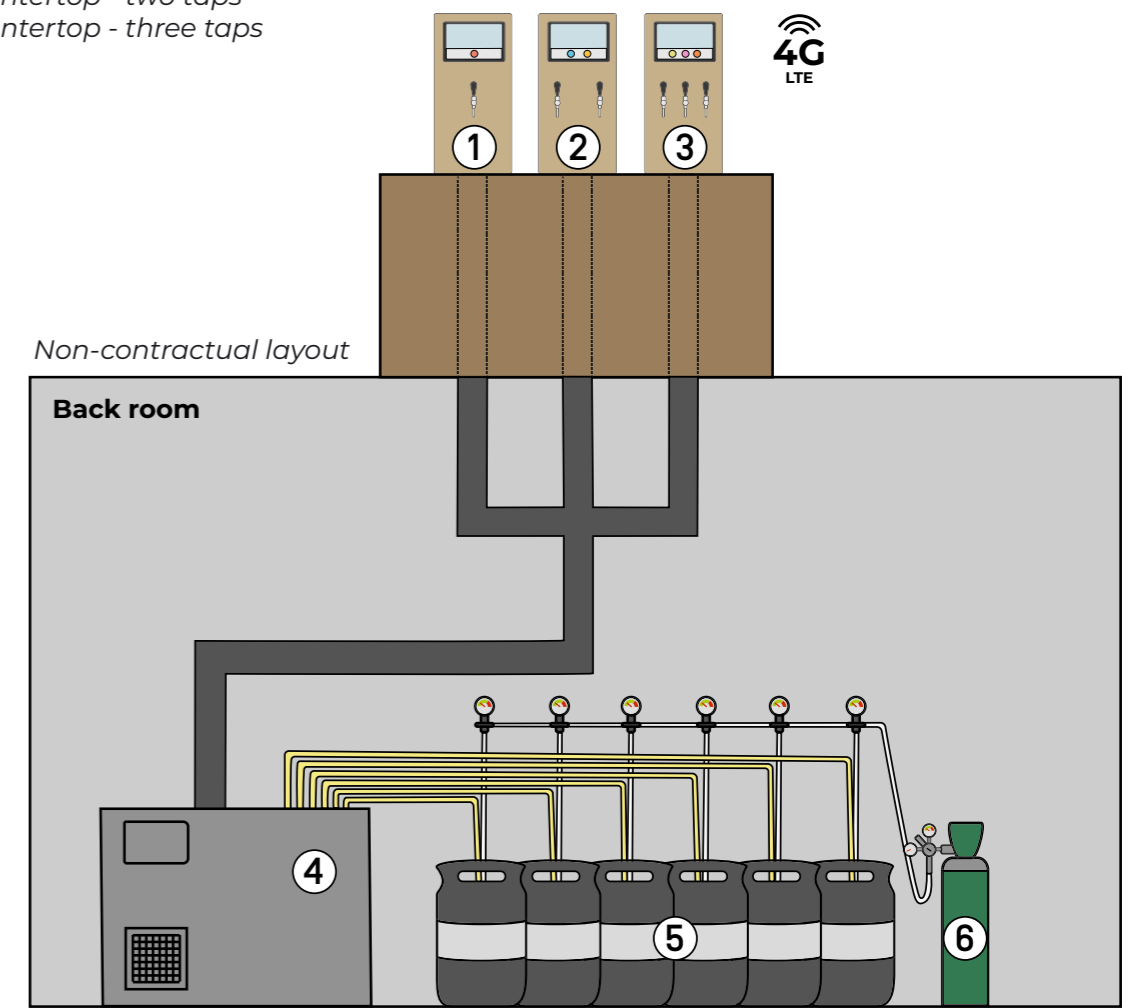

Recommended height for the counter:
850 mm (min.) & 1'000 mm (max).



Only compatible with Drinkotec solutions

Cashless matters

Self-payment integration

VENDING & SELF-SERVICE

Transform your Drinkotec free dispensing systems into a cashless self-service unit.

Choose your payment method.
One integration possibility per product.

- ✓ Credit card*
- ✓ QR code
- ✓ Employee badge
- ✓ Remotely switch between free-dispensing or self-payment





Onyx Self/5000 Integra Custom integration**



*Direct payment with major credit & debit cards.

**Contact us to know if your card management system is already integrated. The integration of a new management system is possible on demand.



Connected equipment to Loop³⁶⁰ Analytics

Dimensions

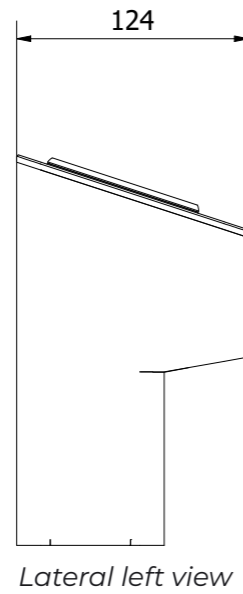
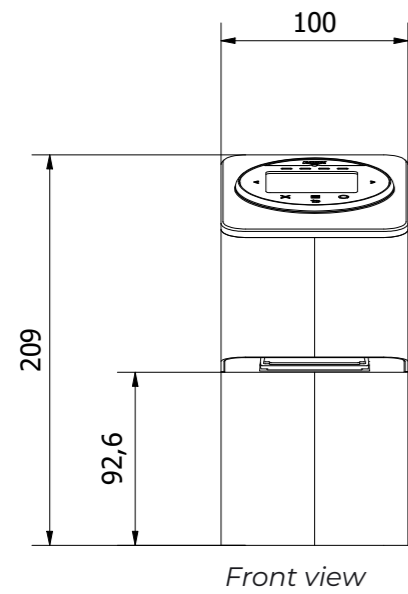

Main features

- ✓ **One integration possibility** per product
- ✓ Credit & debit cards, **direct payment** with **major credit/debit cards**
- ✓ RFID card with **prepaid credit**

- ✓ Corporate cards, **integrate your own RFID system**
- ✓ **QR Code**, generated to be printed and **used on the BevPay terminal**

Technical features

- ✓ **Dimensions**
height: 209 mm
width: 100 mm
depth: 124 mm

- ✓ **Connection to dispensing machine**
RS-232

Nayax - Onyx Compatibility

Nayax



NEO with Nayax

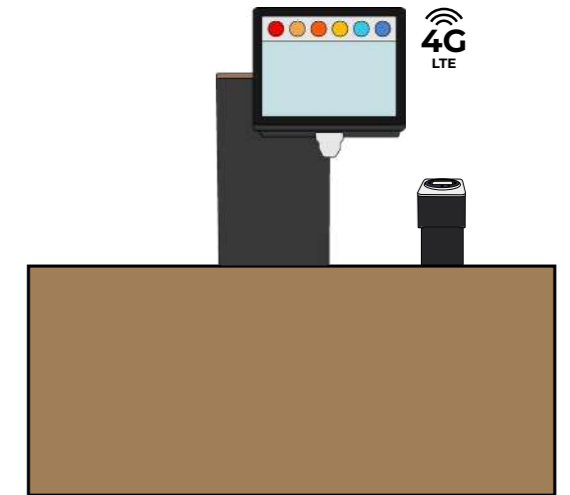

Vision PX with Nayax

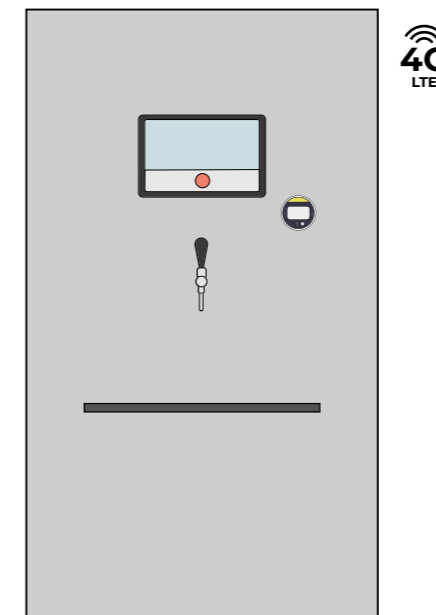

The Wall Kit with Nayax

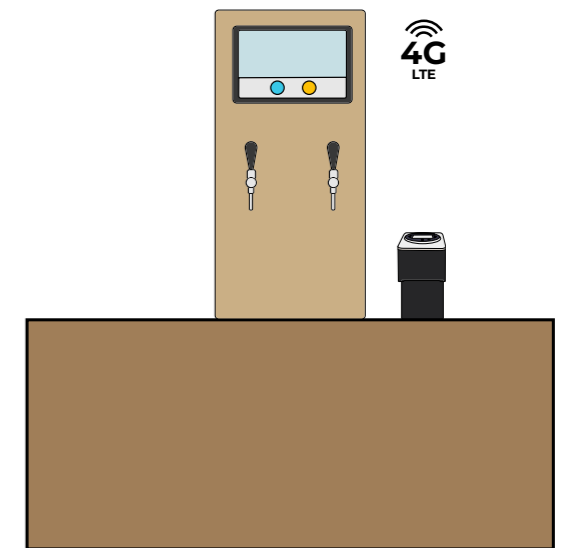

The Wall Countertop with Nayax

BEVPAY
Technical specifications

Dimensions

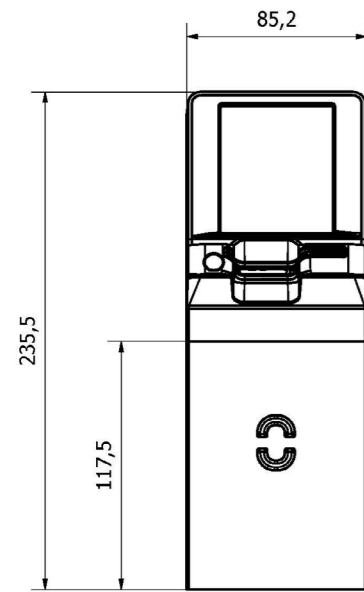

Front view

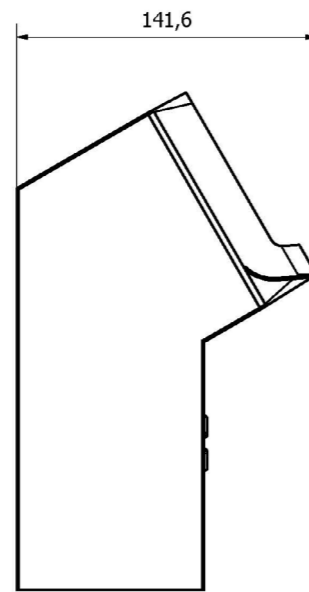

Lateral left view

Main features

- ✓ One integration possibility per product
- ✓ Credit & debit cards, direct payment with major credit/debit cards
- ✓ RFID card with prepaid credit
- ✓ Corporate cards, integrate your own RFID system
- ✓ QR Code, generated to be printed and used on the BevPay terminal

Technical features

- ✓ Dimensions
height: 235,5 mm
width: 85,2 mm
depth: 141,6 mm
- ✓ Connection to dispensing machine
RS-232

Ingenico - Self/5000 Compatibility

ingenico



NEO with Ingenico

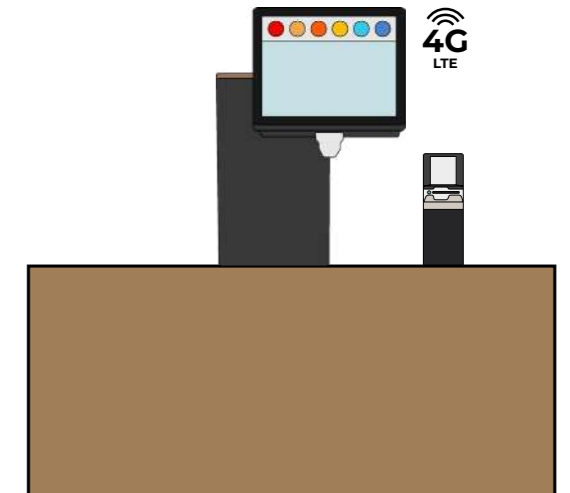

Vision PX with Ingenico

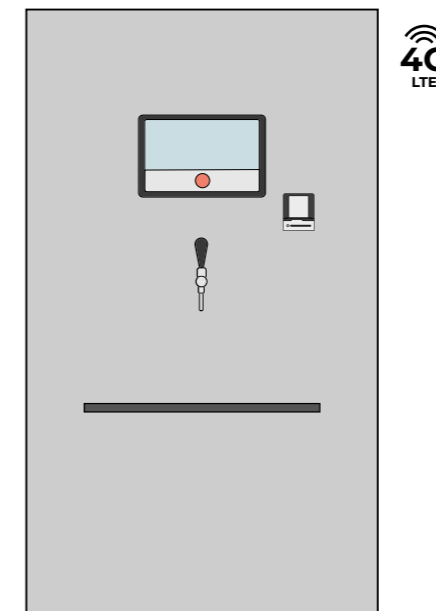

The Wall Kit with Ingenico

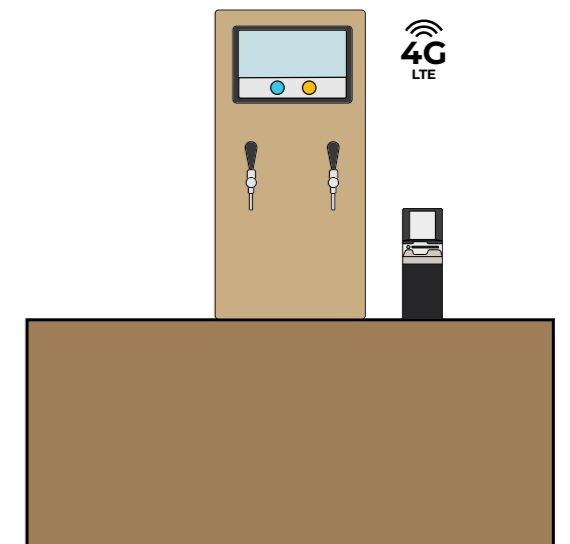

The Wall Countertop with Ingenico

BEVPAY
Technical specifications



Data AI apps

Loop³⁶⁰ Analytics for
Vending and HoReCa owners & staff
Sales, technical, logistic & marketing for
brands

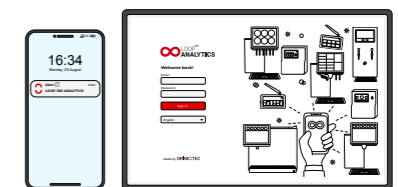

Drinkotec IoT Infrastructure

Cloud & software to **remotely** setup, monitor and control installations



Unifying all beverage data into Loop³⁶⁰ Analytics

Loop³⁶⁰ Analytics can act as your data concentrator; bringing **all your IoT data into one single place** for advanced analytics and automated workflows for increased business performance not only at the point of sales but also for your Sales, Technical, Logistic and Marketing Teams.

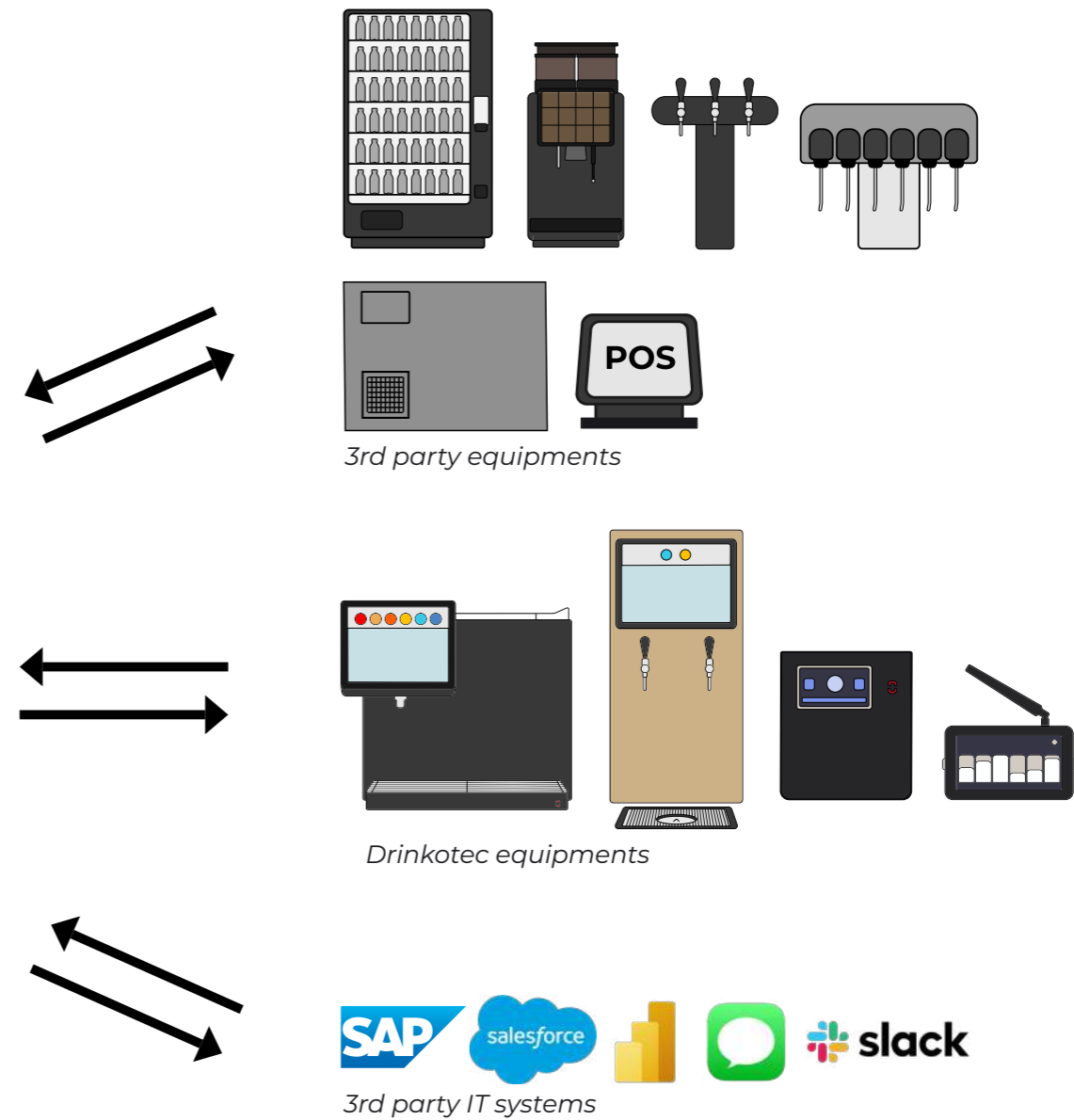

LOOP³⁶⁰ ANALYTICS

Main & unique features to operational KPIs
**Compatible with all beverage equipments
 in the market**



Data & AI matter

Discover Loop³⁶⁰ Analytics



ONE UNIQUE BEVERAGE IOT PLATFORM

With all the equipments and sides connected, Loop³⁶⁰ Analytics maintains high level of remote monitoring.

This allows staff, owners and beverages brands teams (sales, marketing, logistic and technicals) to **track, monitor** and **understand** in order to **perform** better.

With **40 years of expertise** in beverage dispensers, Drinkotec knows the industry's needs inside out. Over the years we created **an 360° ecosystem** where **data matters**.

All our devices are connected to a unique secured analytics platform: **LOOP³⁶⁰ ANALYTICS**.

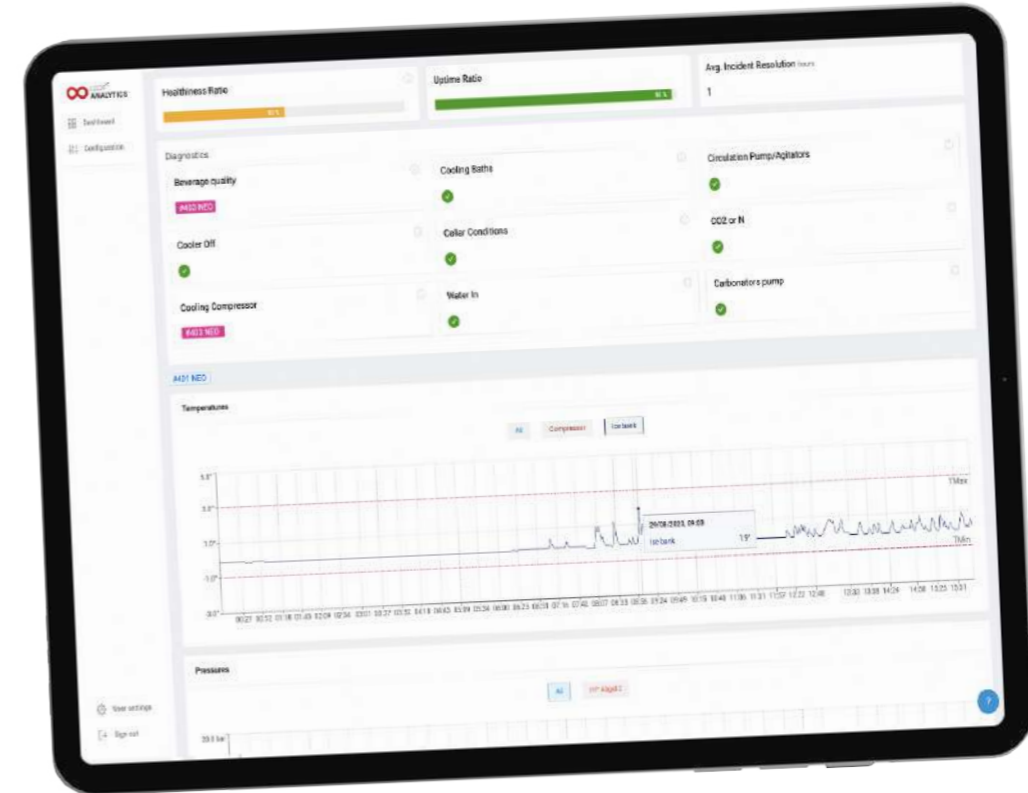

Vending and HoReCa staff & owners

- + Track dispensing of your products dispensed vs sold in real time
- + Track inventory for your products
- + Promote new beverages at the dispenser
- + Incidents alerts
- + Remotely debugging incidents
- + Remote configuration
- + Equipment status update

Beverage brands

Sales teams

- + Track your sales contracts and volume targets in real time
- + Track installation goals /profitability as signed and agreed in contracts
- + Track dispensing of your products dispensed vs sold in real time

Technical teams

- + Incidents alerts
- + Remotely debugging incidents
- + Remote configuration
- + Equipment status update
- + Asset tracking on real-time geo-localisation
- + Teams territory management

Logistic teams

- + Real-time Inventory: Monitor and automate inventory in all your HoReCa clients in the field
- + Routing & planning optimization: With the platform's real-time data, organize your deliveries strategically
- + Supply predictability

Marketing teams

- + Video content impacts your products sales **right at the dispensers** and **measure the impact** of it on product selection
- + Promote new beverages at the dispenser
- + Perform A/B testings
- + Sell strategic Ad spaces/locations to 3rd party brands and **create new revenue streams**

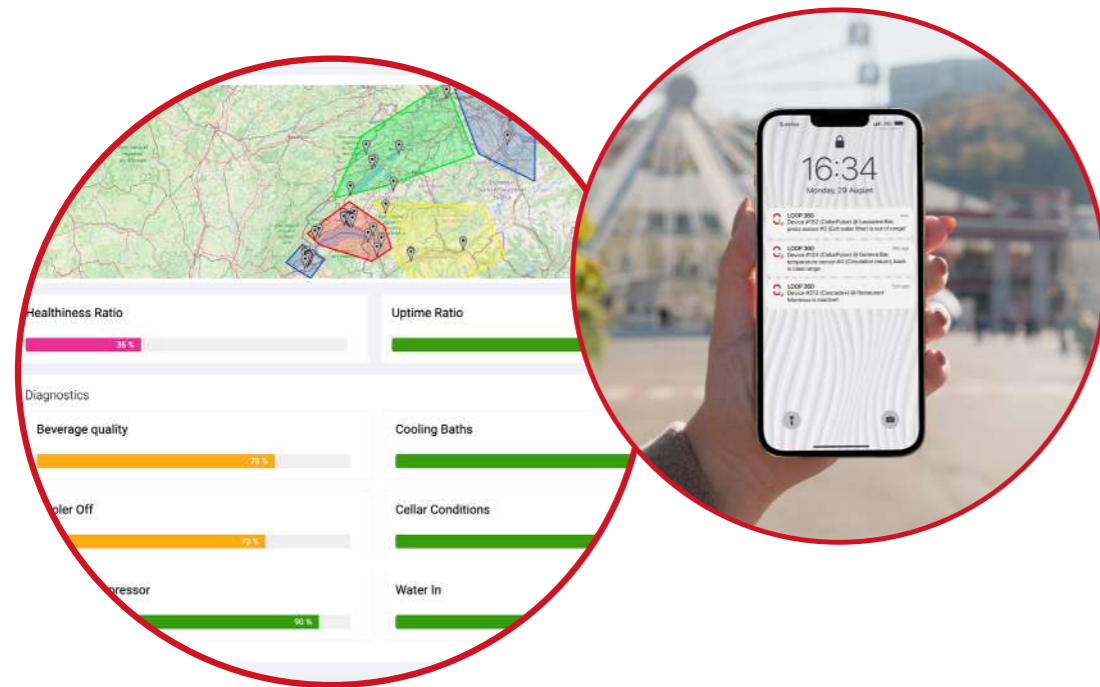



Counter cutting drawings

and counter space requirements

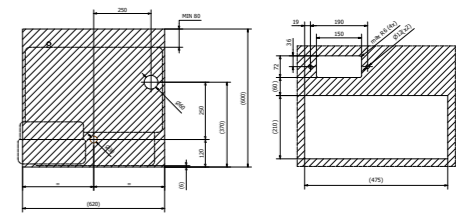

NEO

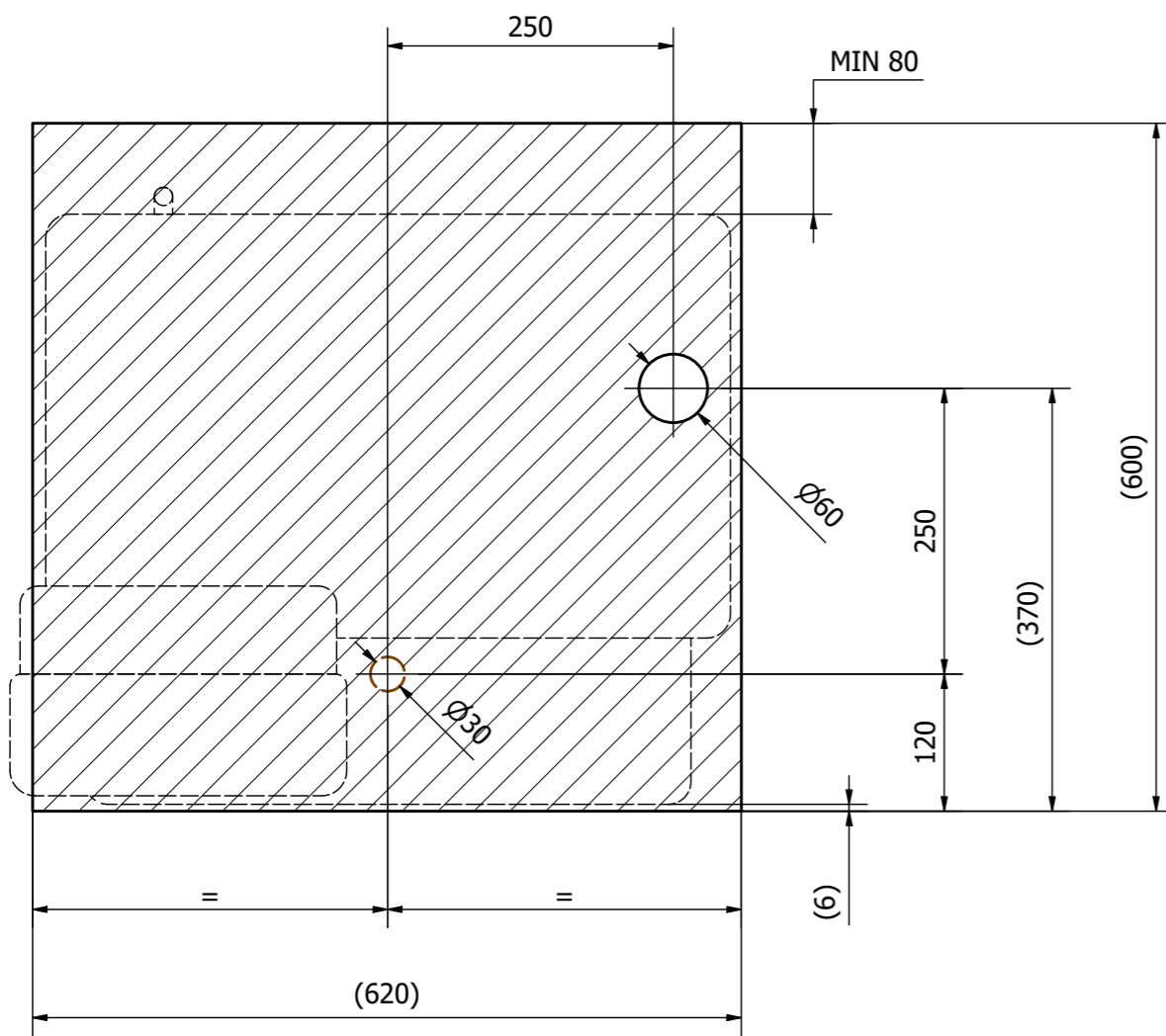
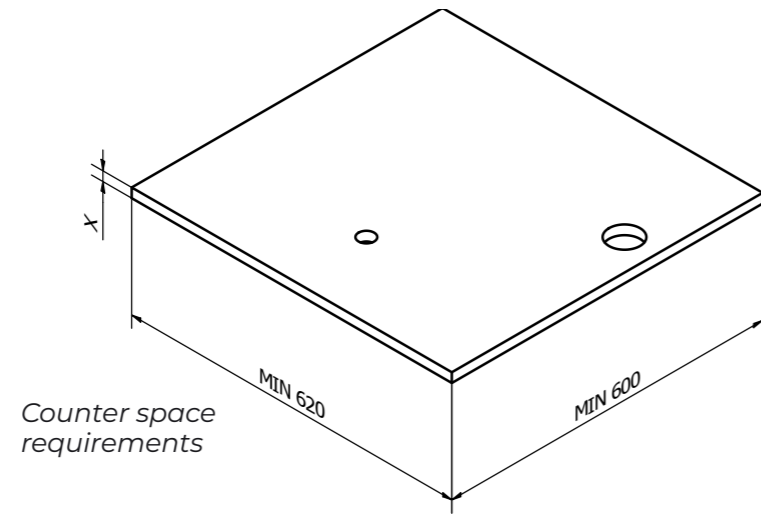
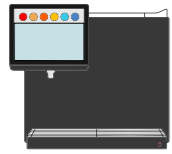

VISION PX



Tray type ETS-2

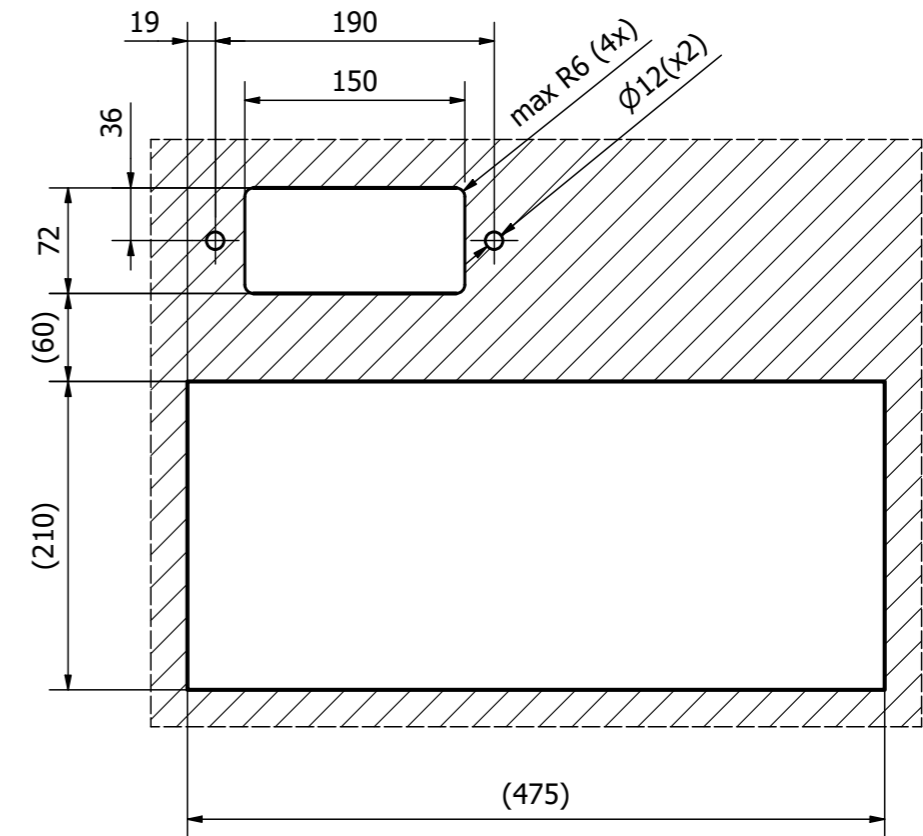
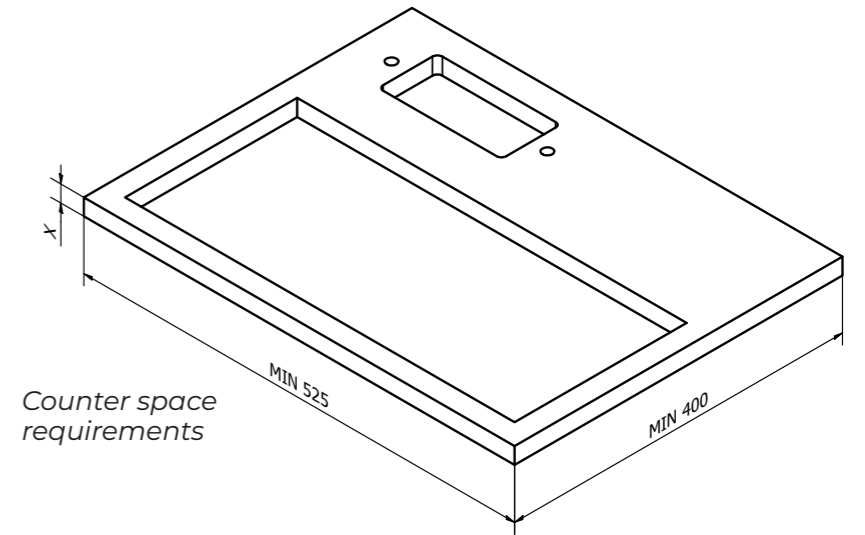

THE WALL

Kit mounting

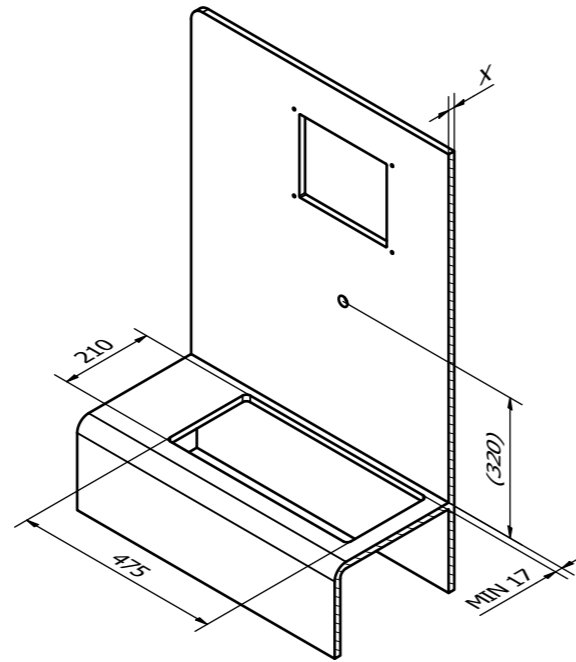

Counter space requirements

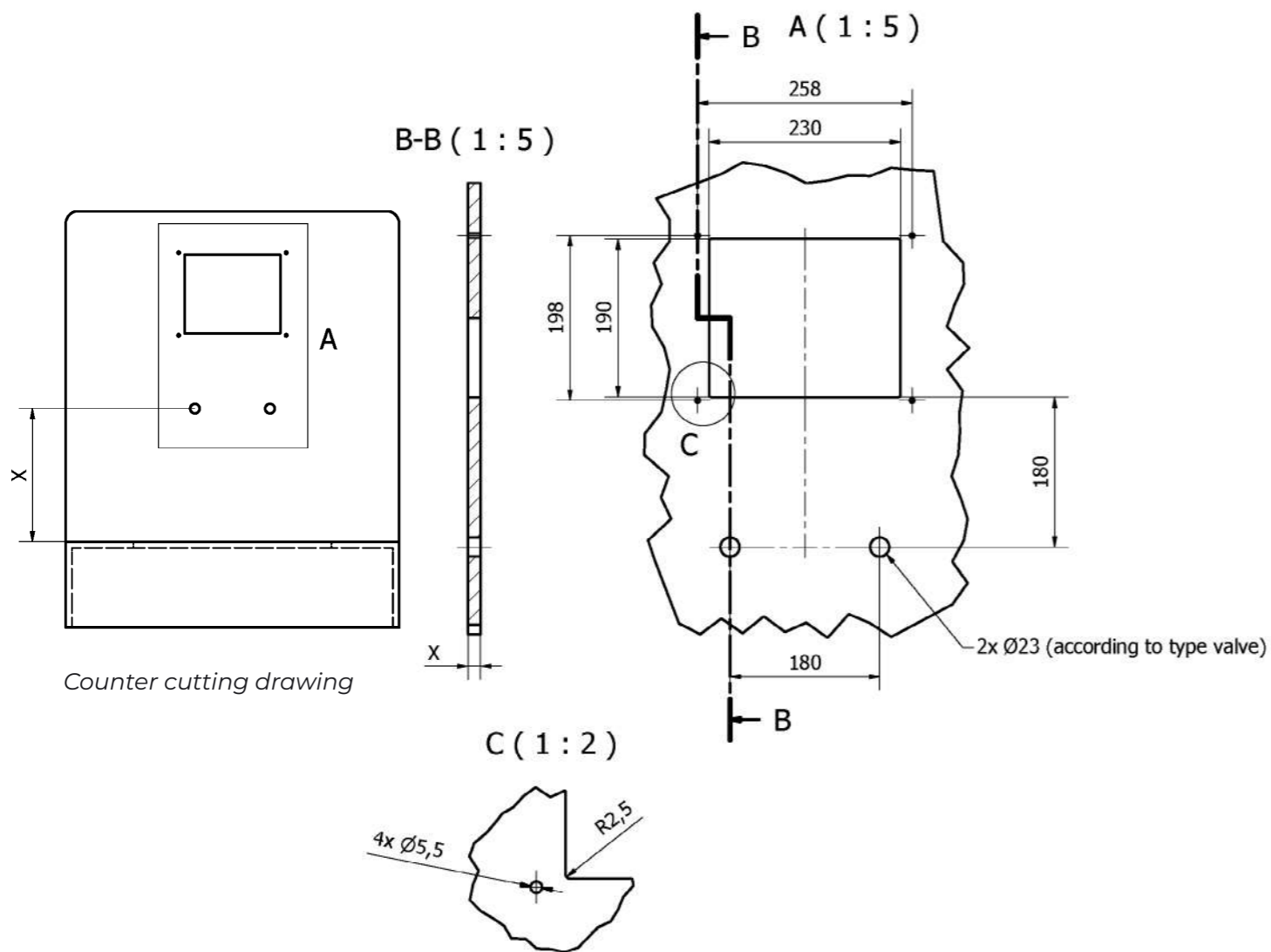

Counter cutting drawing

THE WALL

Countertop mounting



If The Wall Countertop has 3 taps, a larger tray will be needed (type ETS-2).

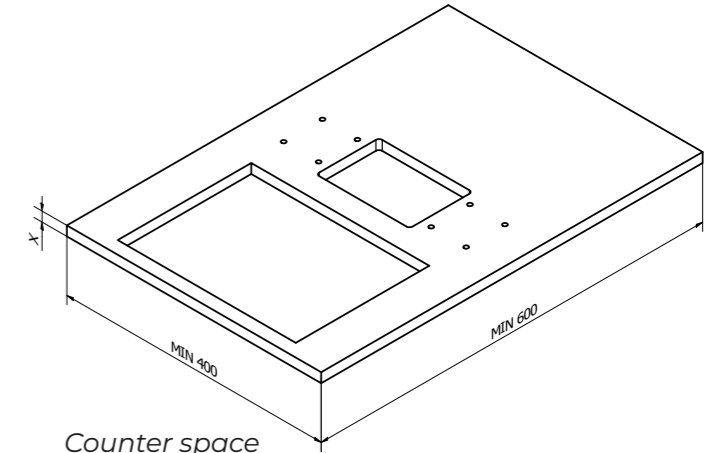

Counter space requirements

For 1 or 2 taps with a tray type ETS-1.

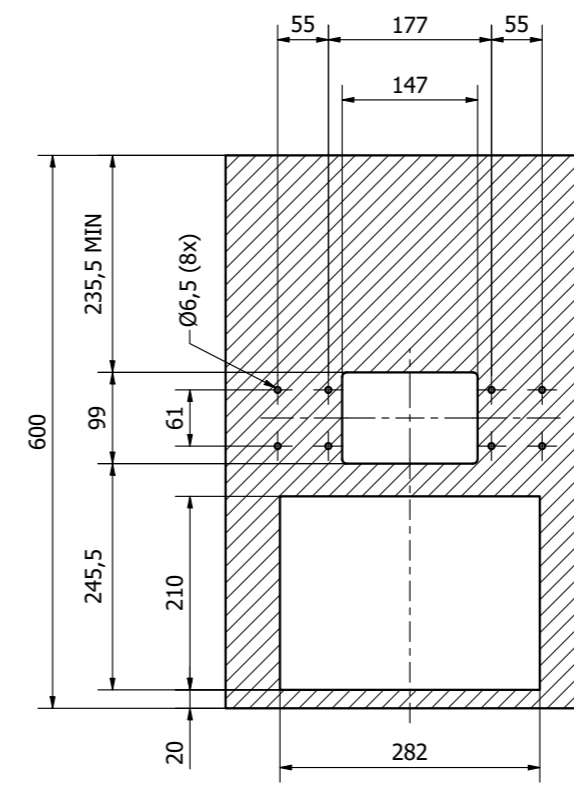

Counter cutting drawing

For 3 taps with a tray type ETS-2.

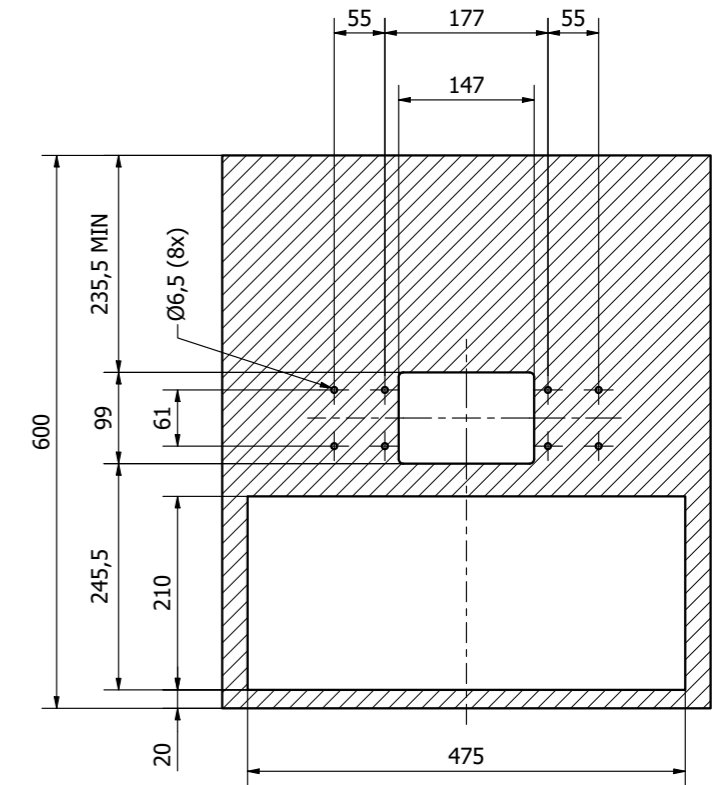

BEVPAY

Nayax - Onyx

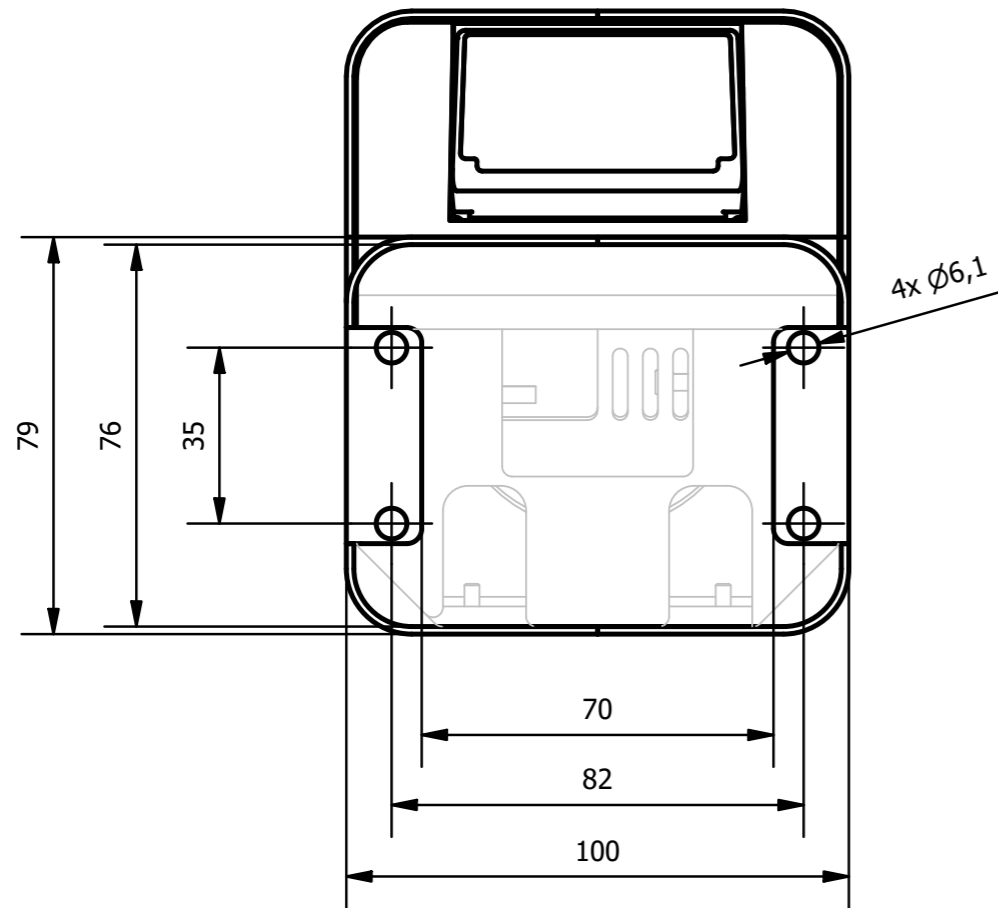

Bottom view

BEVPAY

Nayax - Onyx

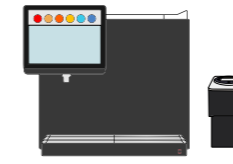

NEO with Nayax



Vision PX with Nayax

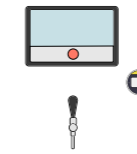
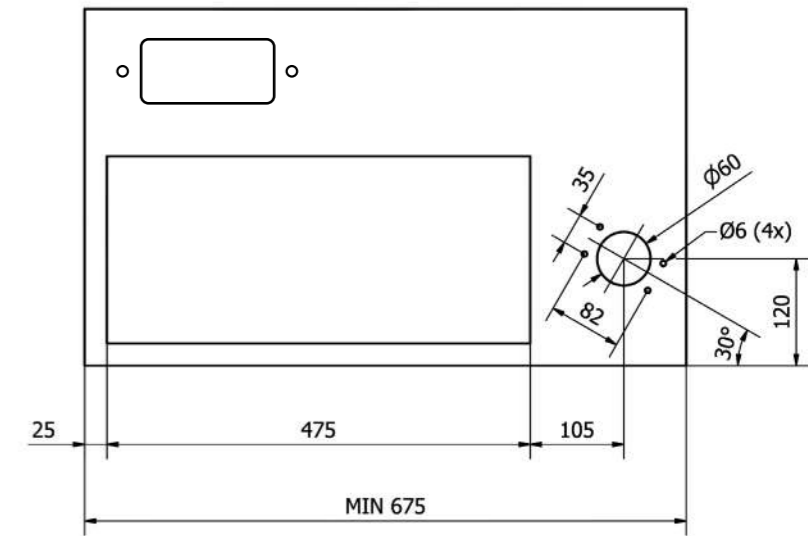
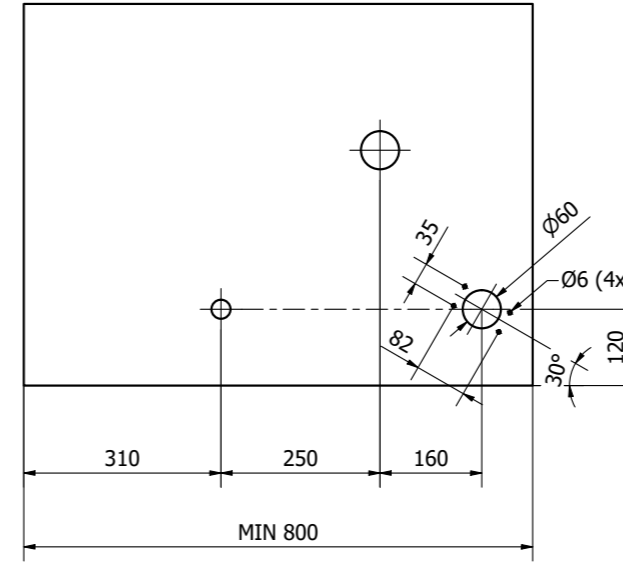

The Wall Kit with Nayax

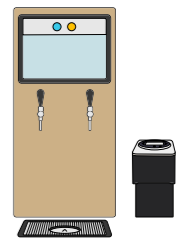

The Wall Countertop with Nayax

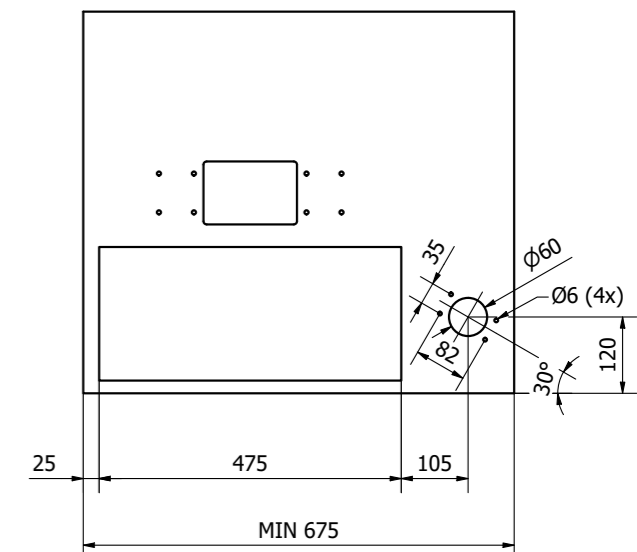
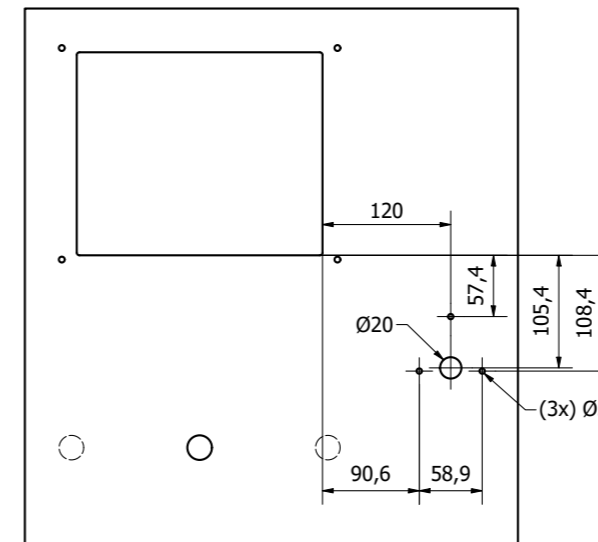

BEVPAY

Ingenico - Self/5000

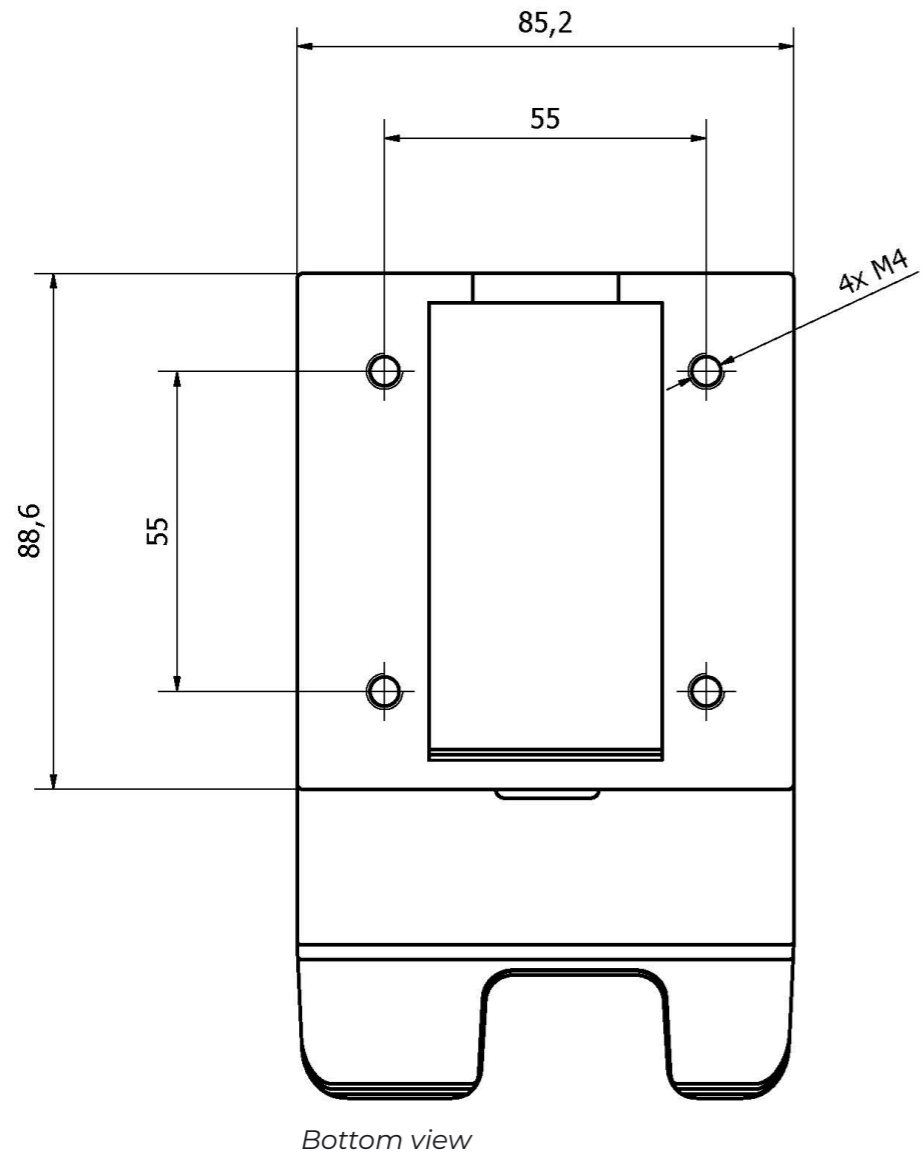

BEVPAY

Ingenico - Self/5000



NEO with Ingenico

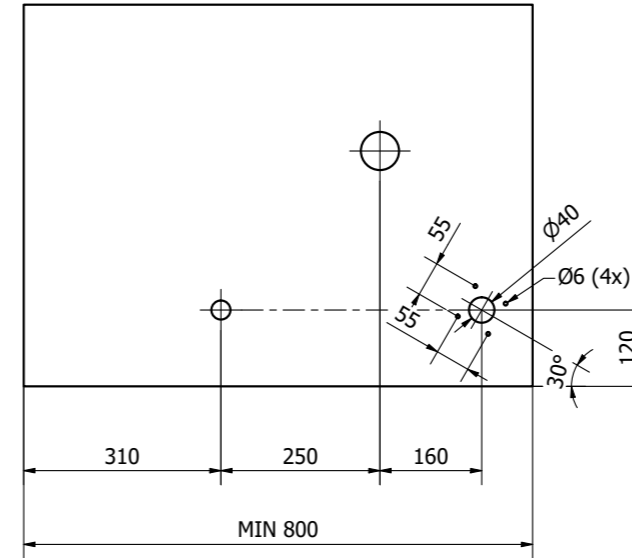

Vision PX with Ingenico

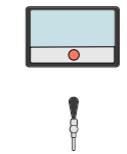
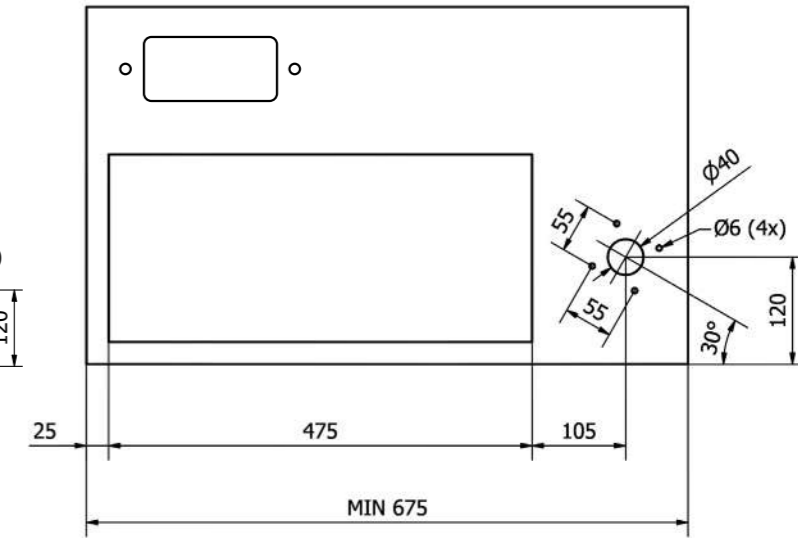

The Wall Kit with Ingenico

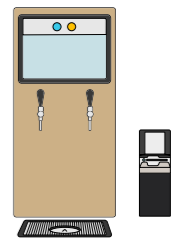
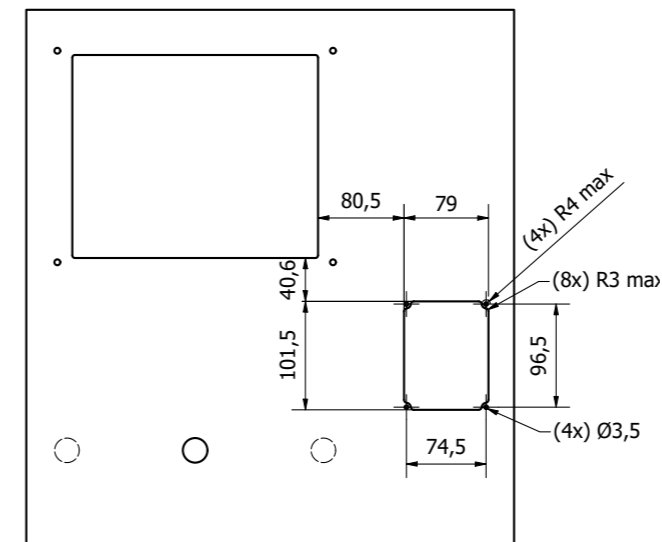

The Wall Countertop with Ingenico

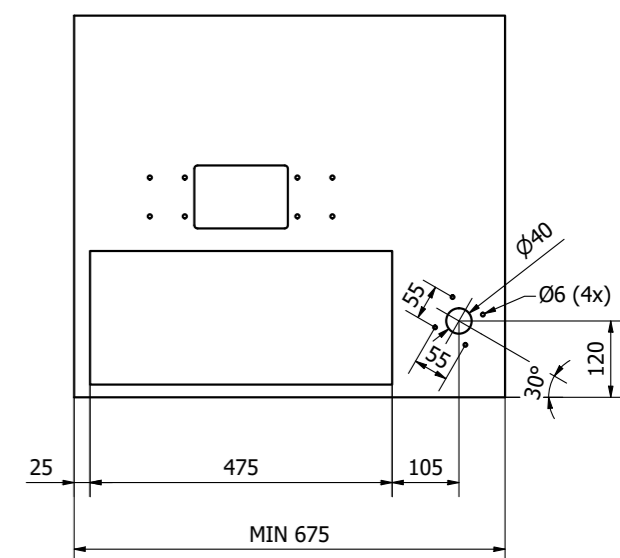



Find all details on our website
www.drinkotec.ch/data-privacy

Vending & Self-service

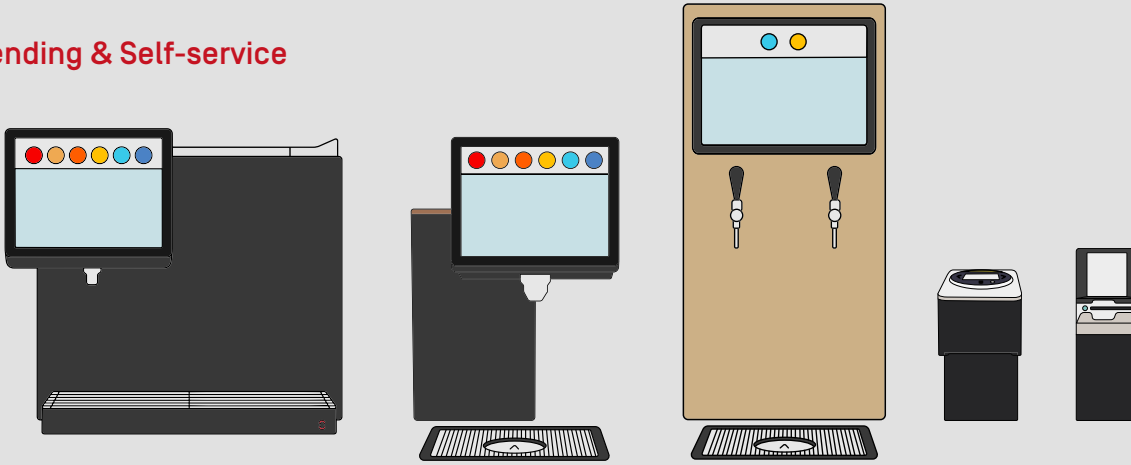

HoReCa Staff operated

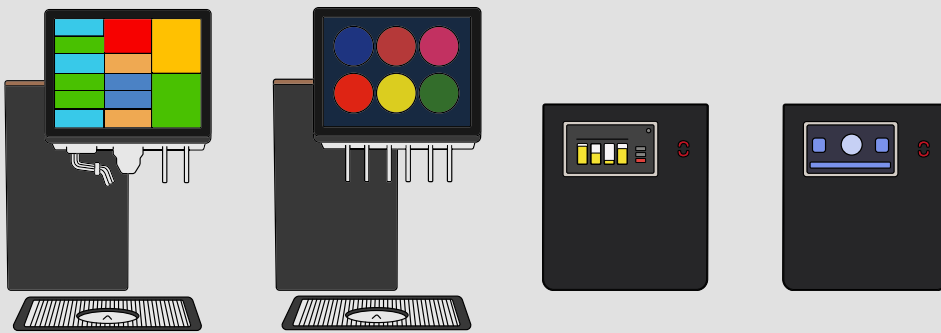

Telemetry & IoT Software

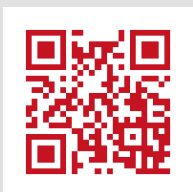
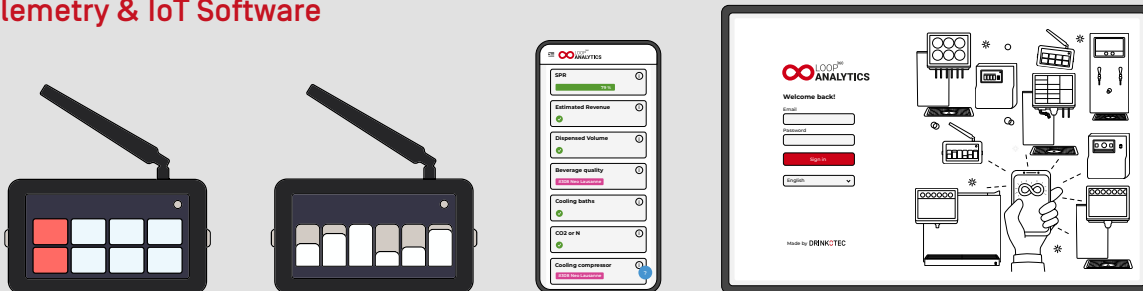

DRINKOTEC

Drinkotec Sàrl - CH 1260 Nyon
+41 22 994 21 21 - www.drinkotec.ch